

# BLINDS FENCE ATLAS

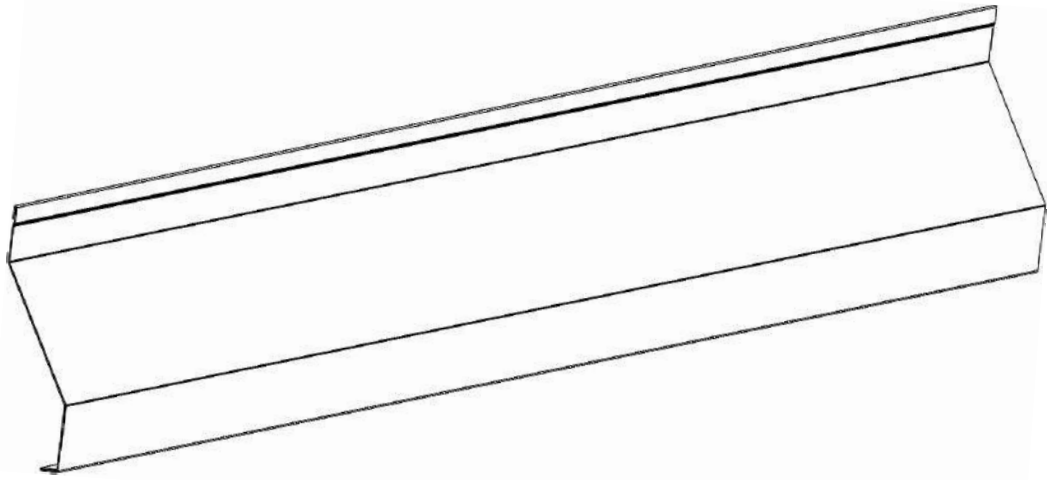

# ASSEMBLY INSTRUCTIONS

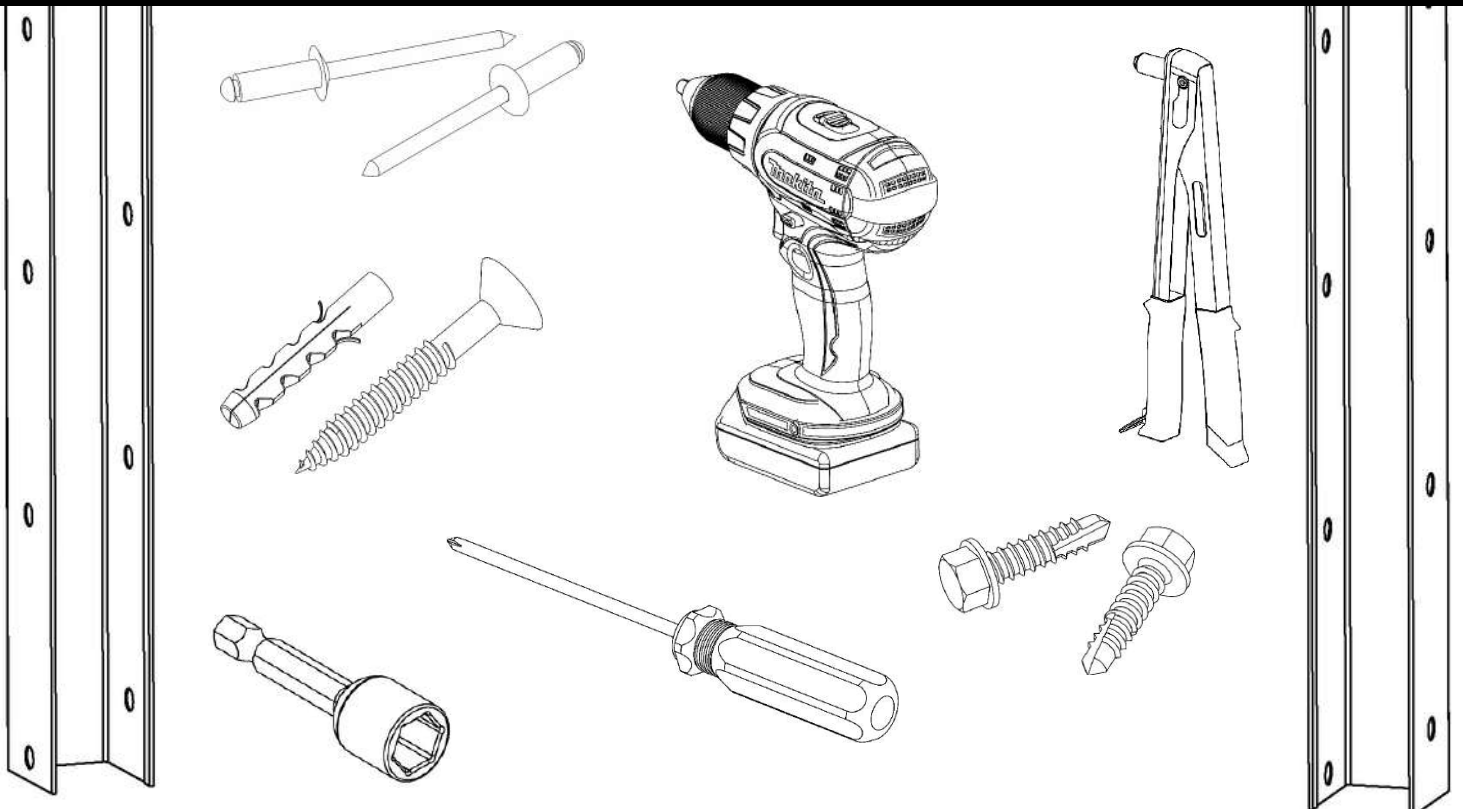

# INCLUDED ELEMENTS

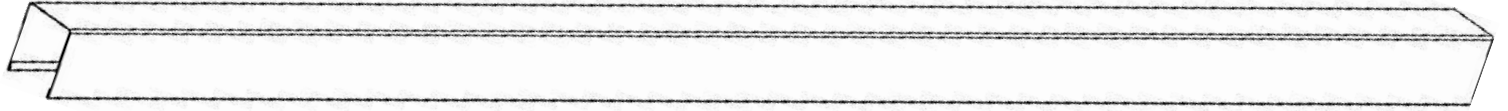

**HORIZONTAL "U" PROFILE**

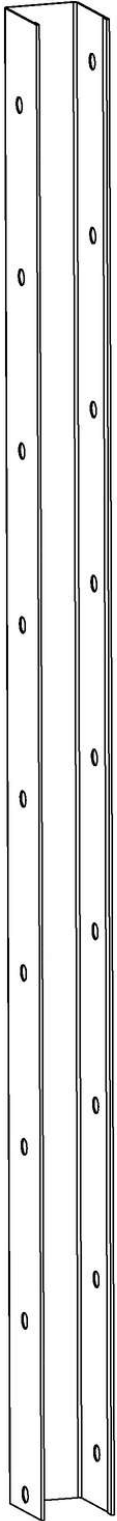

**VERTICAL  
"U"  
PROFILE  
LEFT**

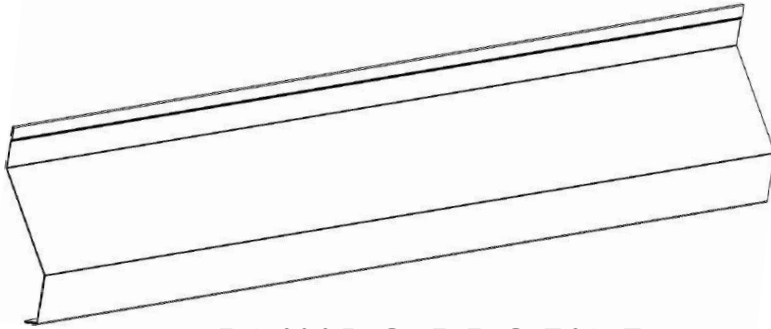

**BLINDS PROFILE**

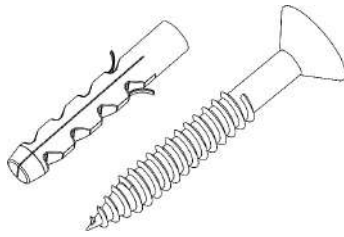

**PLUGS +  
SCREWS**

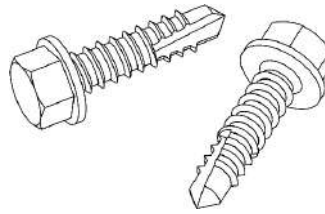

**SELF-DRILLING  
SCREWS**

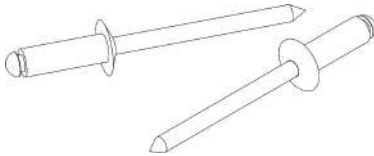

**POP-RIVETS**



**CORNICE**



**BACK  
SUPPORT  
PROFILE**

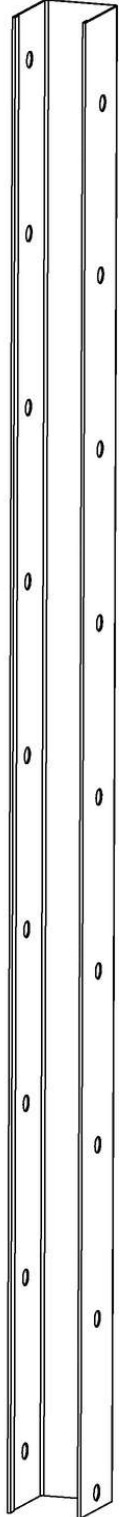

**VERTICAL  
"U"  
PROFILE  
RIGHT**

# NECESSARY TOOLS

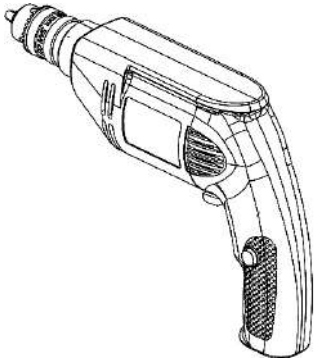

**DRILLING  
MACHINE**

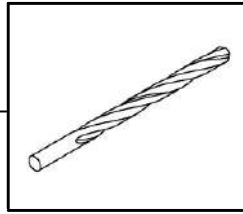

**Drill  $\varnothing$ 4 for  
METAL**

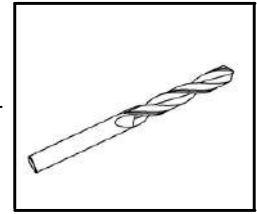

**Drill  $\varnothing$ 10 for  
CONCRETE**

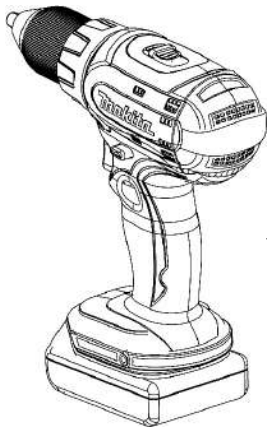

**SCREWDRIVER**

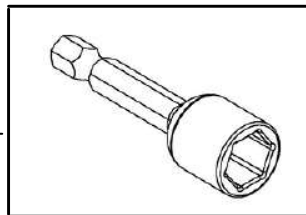

**Tubular Key  
 $\varnothing$ 4**

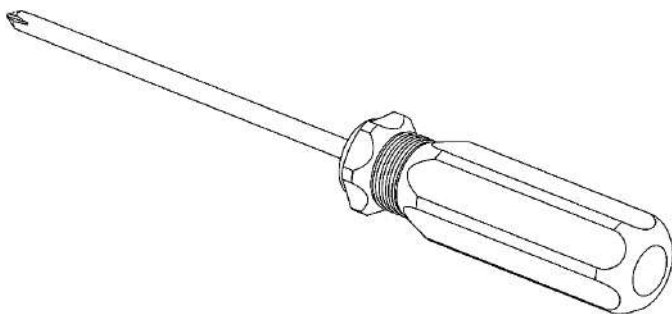

**STAR SCREWDRIVER | PH2**

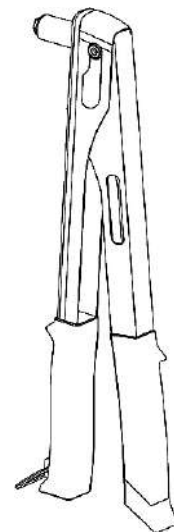

**POP-RIVETS PLIERS /  
GUN**

# STEP 1 (a)

## INSTALLATION OF VERTICAL "U" PROFILES

Concrete or Brick Pillars

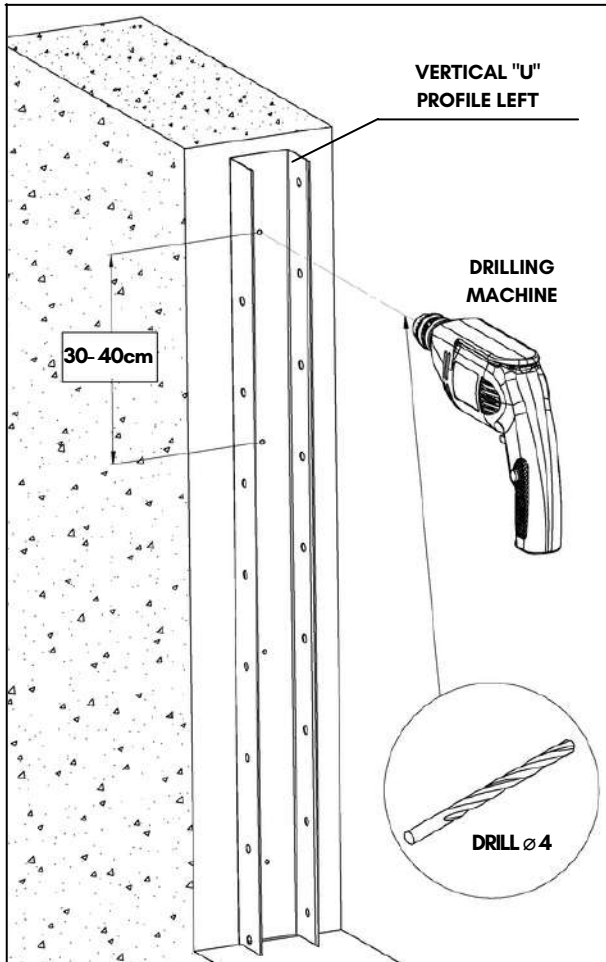

DRAWING 1

1

Position the Left Vertical "U" Profile on the post so that the opening hole of the profile is oriented towards the panel.

It is not necessary to distance the Vertical "U" Profile from the base.

2

Maintaining the position of the Left Vertical "U" Profile on the post, use a drilling machine with a  $\varnothing 4$  drill, designed for perforating metal, drill the Vertical "U" Profile towards the post in steps of 30-40cm.



**Keep the profile firmly in place, throughout the drilling process, to avoid its repositioning.**

The drilling of the Vertical "U" Profile in position on the post will leave traces of the reference points necessary for the subsequent perforation of the post.

3

After finishing the drilling process, remove the Vertical "U" Profile from the post.

You will notice the reference points (in 30-40cm increments) that will serve as markings for drilling the post in the next step.

4

Using a drilling machine with a  $\varnothing 10$  drill designed for perforating concrete, drill the post following the marking.

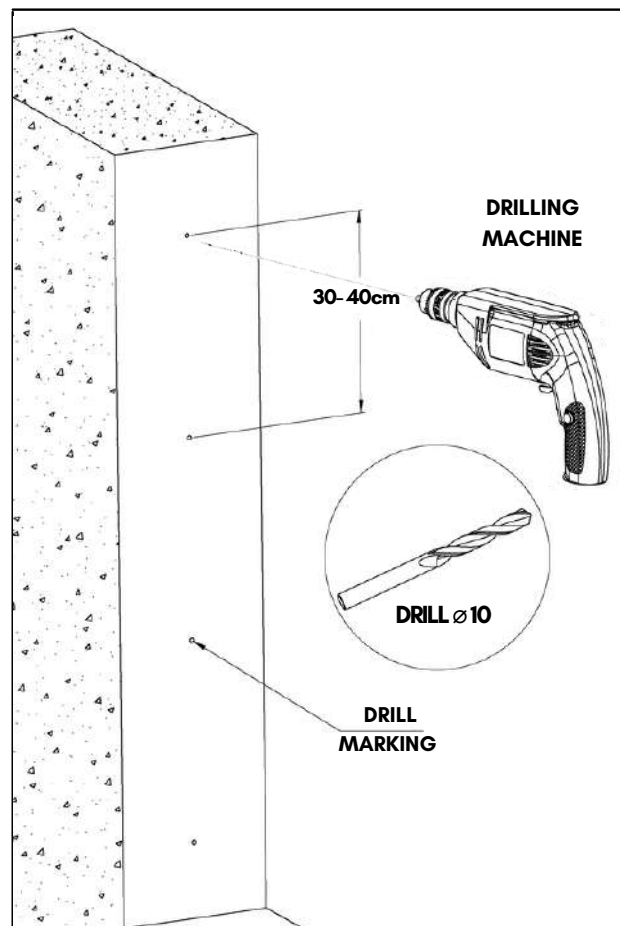

DRAWING 2

**REPEAT THE ABOVE STEPS TO INSTALL THE RIGHT VERTICAL "U" PROFILE**

# STEP 1 (a)

## INSTALLATION OF VERTICAL "U" PROFILES

Concrete or Brick Pillars

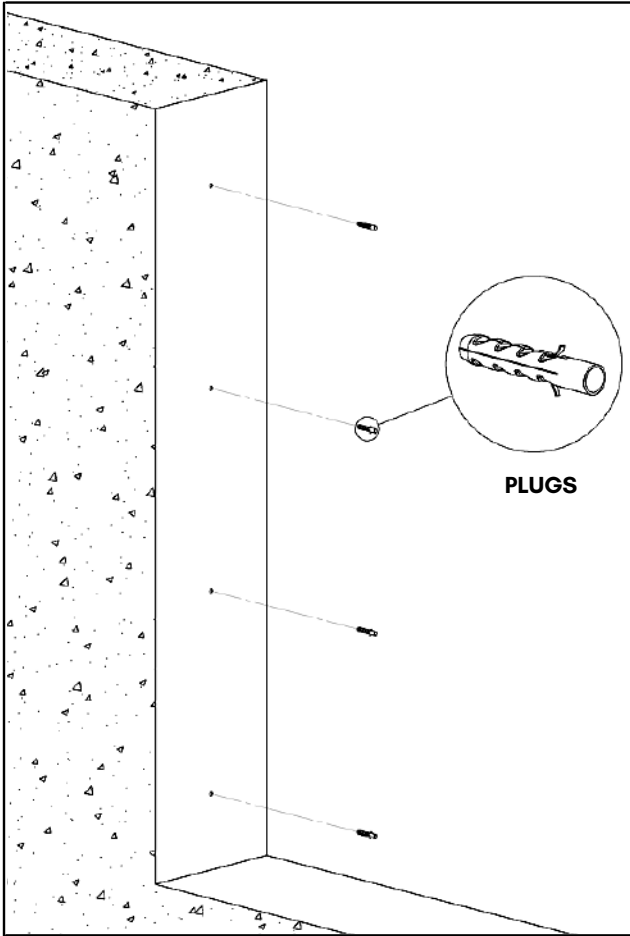

DRAWING 3

5

Insert the dowels into the holes in the post, drilled in the previous step.

---

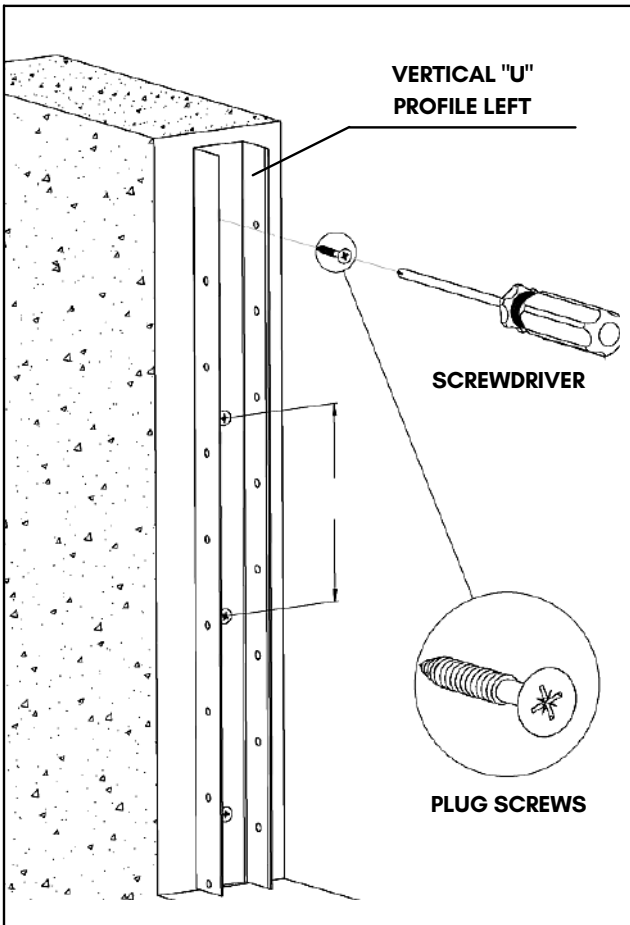

DRAWING 4

6

Position the Left Vertical "U" Profile on the post. Make sure that the fixing holes of the post and those of the Vertical "U" Profile are aligned.

---

7

Using a Star or PH2 screwdriver, insert the dowel screws into the aligned holes and fix tightly by screwing.



**Keep the profile firmly in place, throughout the screwing process, to avoid its repositioning.**

---

**REPEAT THE ABOVE STEPS TO INSTALL THE RIGHT VERTICAL "U" PROFILE**

# STEP 1 (b)

## INSTALLATION OF VERTICAL "U" PROFILES

Metal Pillars

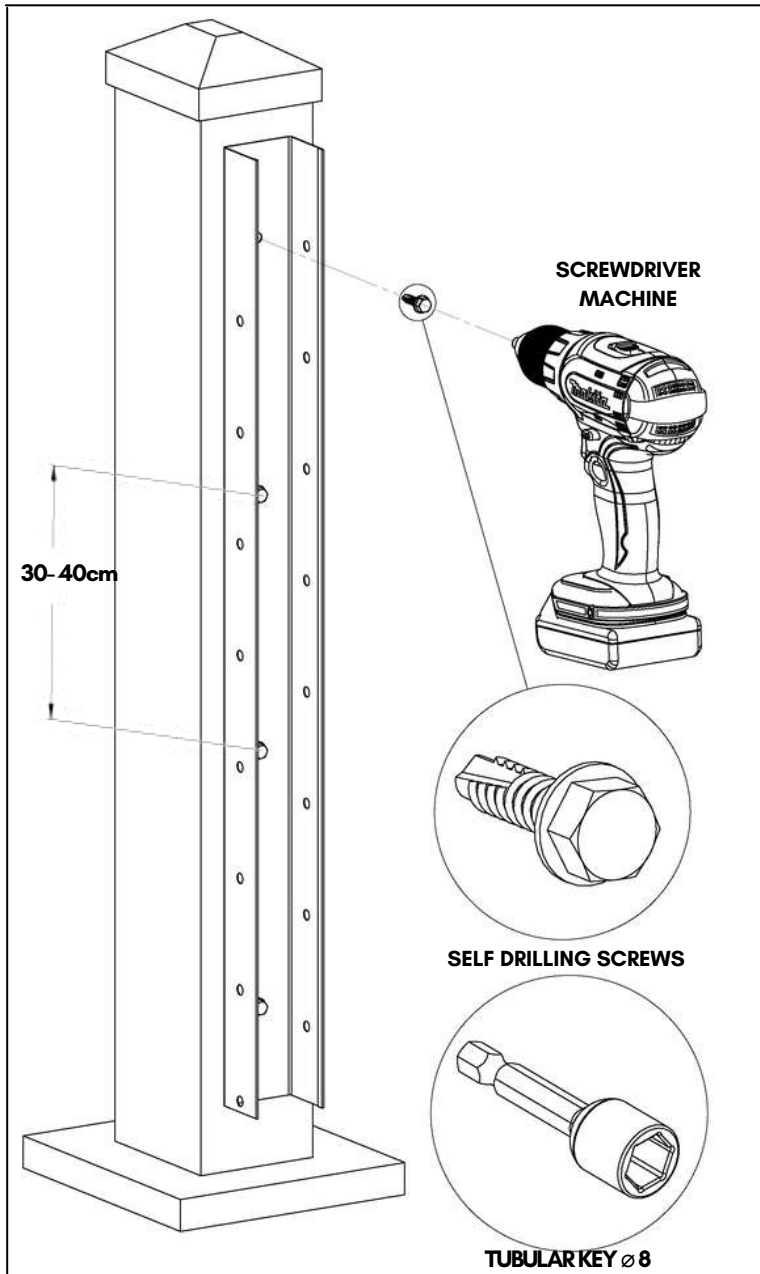

**DRAWING 5**

- 1 Position the Left Vertical "U" Profile on the post so that the opening hole of the profile is oriented towards the panel.

It is not necessary to distance the Vertical "U" Profile from the base.

- 2 Using the Screwdriver Machine with the  $\varnothing 8$  tubular key designed for perforating metal, screw the Vertical "U" profile of the post in steps of 30-40cm with self-drilling screws.

 **Keep the profile firmly in place, throughout the drilling process, to avoid its repositioning.**

**REPEAT THE ABOVE STEPS TO INSTALL THE RIGHT VERTICAL "U" PROFILE**

# STEP 2

## INSTALLATION OF BLINDS PROFILES

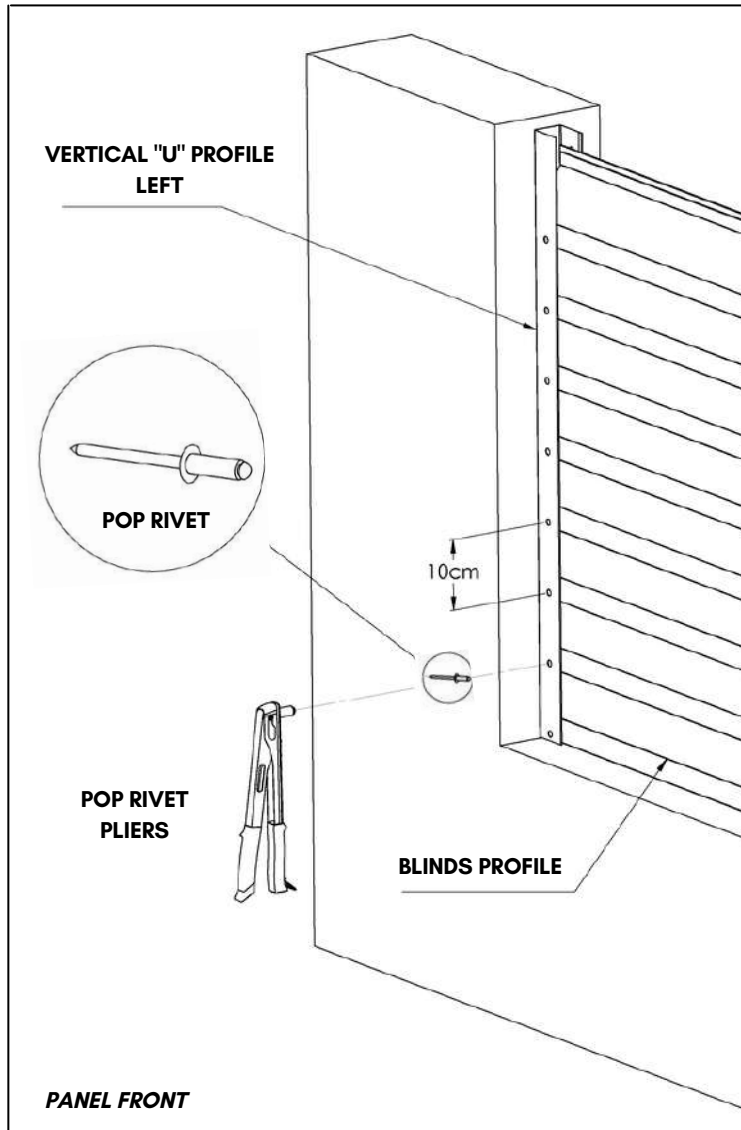

**DRAWING 6**

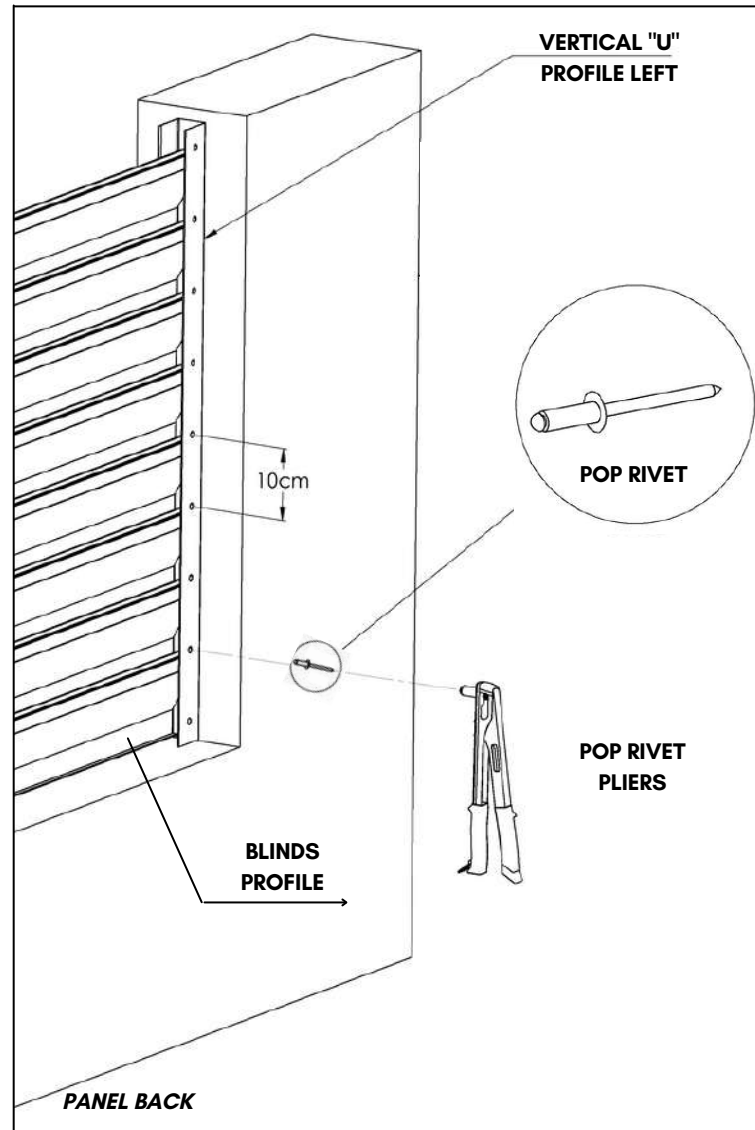

**DRAWING 7**

- 1 Start assembling the Blinds Profiles from bottom to top.

The Vertical "U" profiles (Right + Left) have mounting holes made in the factory to facilitate and speed up the installation process.

- 2 Position the Blinds Profile between the Vertical "U" Profiles.

- 3 Using the Drilling Machine with a  $\varnothing 4$  drill designed for metal, drill the Blinds Profiles through the pre-made factory holes of the Vertical "U" Profiles.

- 4 Align the fixing holes of the Blind Profiles and the Vertical "U" Profiles.

Insert the pop-rivet into the pliers / rivet gun.

Place the Pliers / Rivet Gun perpendicular to the hole and rivet it in the 4 pre-drilled fixing points:

2 in front (left + right)

2 in back (left + right)



Keep the profiles firmly in place, throughout the riveting process, to avoid their repositioning.

**REPEAT THE ABOVE STEPS TO INSTALL ALL BLINDS PROFILES**



# STEP 3 (a)

## INSTALLATION OF THE BACK SUPPORT PROFILE

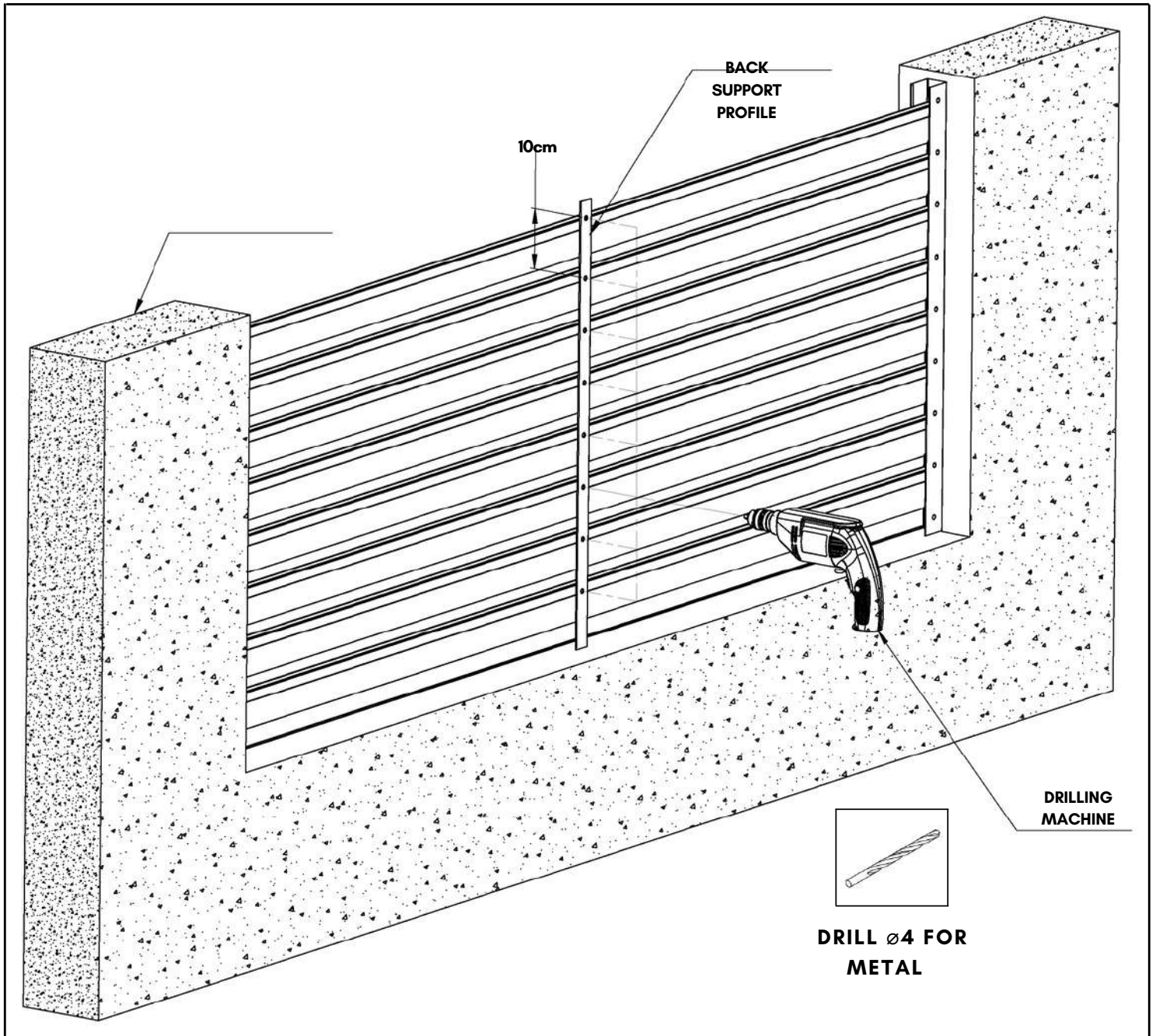

1 Position the Back Support Profile behind the panel, in the middle.

2 Using the Drilling Machine with a  $\varnothing 4$  drill designed for metal, simultaneously drill the Back Support Profile towards the back of each Blind Profile, in the middle.

 1 We recommend starting the drilling process with the first and last row of the Blinds Profile, then continuing with the perforation of the middle rows.

 2 Hold the Back Support Profile firmly in place throughout the drilling process to avoid its repositioning.



# STEP 3 (a)

## INSTALLATION OF THE BACK SUPPORT PROFILE

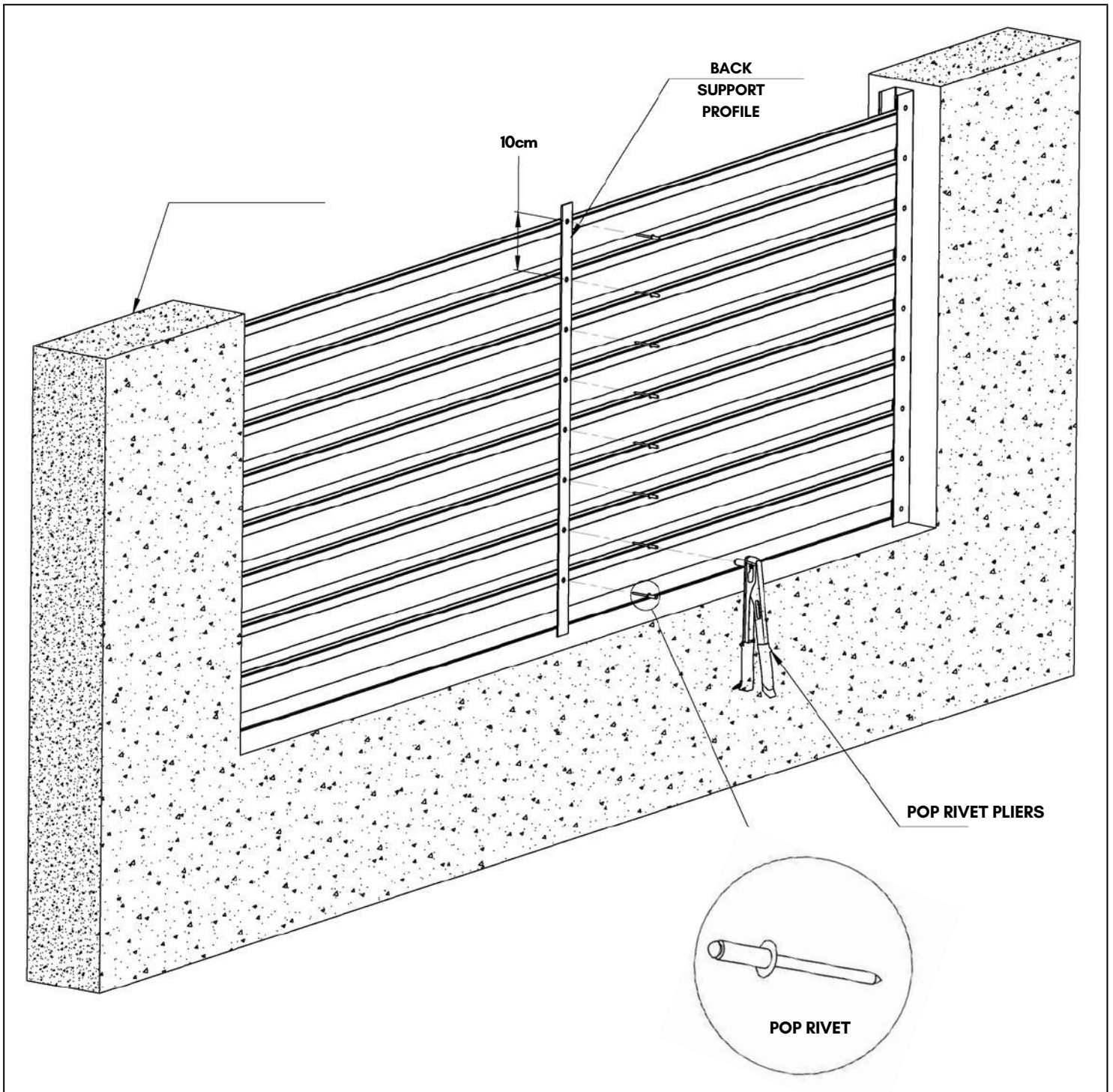

**3** After finishing the drilling process, align the fixing holes of the Back Support Profile with those of the Blind Profiles.

**4** Insert the pop-rivet into the pliers / rivet gun.

Place the Pliers / Rivet Gun perpendicular to the hole and rivet them in the fixing points drilled in the previous step.



Hold the Back Support Profile firmly in place throughout the drilling process to avoid its repositioning.

## STEP 3 (b)

## INSTALLATION OF THE CORNICE

For Concrete or Brick Pillars

1

Position the cornice at the base of the back support profile, in the middle, with the vertical side aligning the middle of the back support profile, and the horizontal side facing the base.



2

Through the prefabricated hole in the middle of the cornice, mark the middle of the hole on the base with a marker. This will serve as marking for drilling in the next step. Remove the cornice from the base.

3

Using the drill machine with the 10-gauge drill bit, designed for perforating concrete, drill the base following the marking.

4

Insert the dowels into the hole in the base drilled in the previous step.

Position the cornice on the base. Make sure that the fixing hole of the base and that of the cornice are aligned. Insert dowel screws into the aligned holes and secure + tighten.

5

Using the drill machine with the 4-hole drill, designed for perforating metal, drill the back support profile through the 4 holes of the cornice.

6

After finishing the drilling process, insert a pop-rivet into the pliers/riveting gun. Place the pliers/riveting gun perpendicular to the hole and rivet into the fixing points drilled in the previous step.

# STEP 4

## INSTALLATION OF THE HORIZONTAL "U" PROFILE

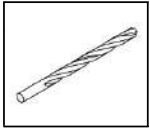
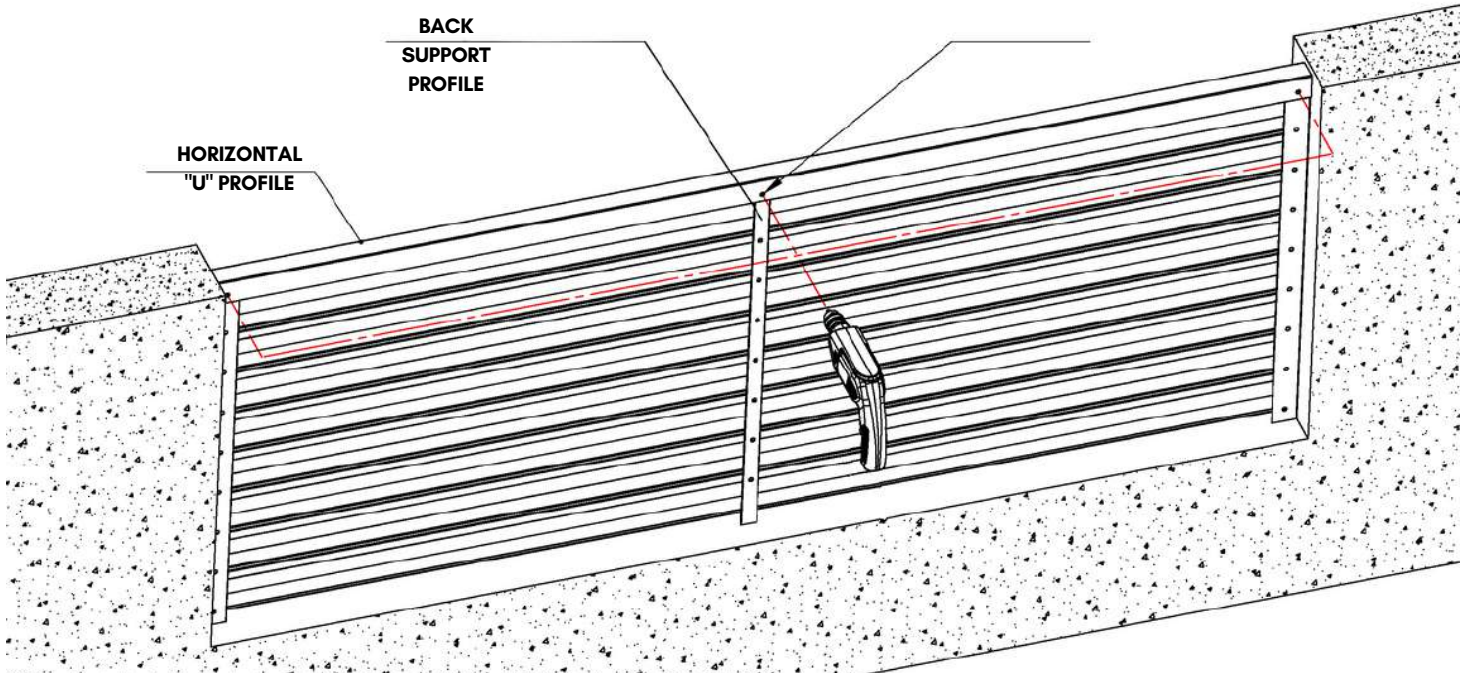

DRILL  $\varnothing 4$  FOR METAL

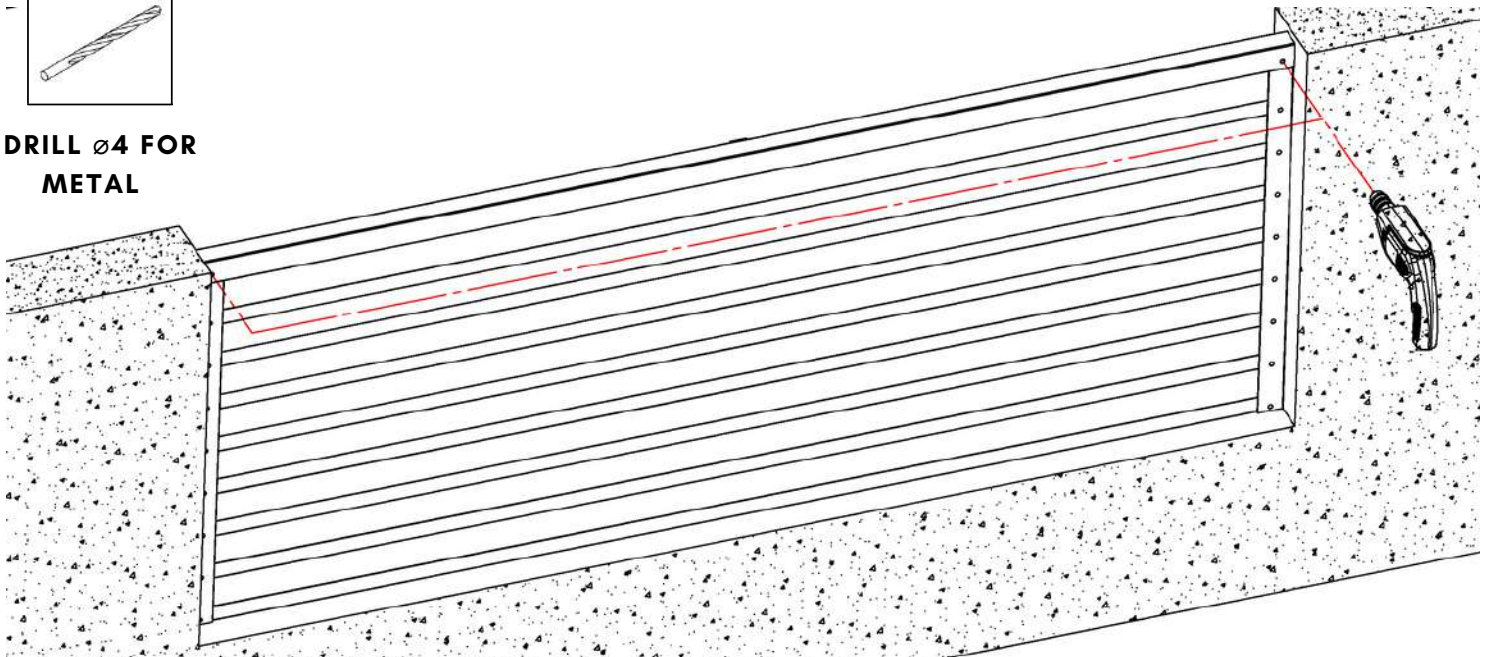

1

Position the Horizontal "U" Profile with the opening hole of the profile facing down, covering the ends of the Vertical "U" Profiles and the Back Support Profile.

2

Using the Drilling Machine with a  $\varnothing 4$  drill designed for metal, simultaneously drill:

1. **Horizontal "U" Profile** and **Vertical "U" Profiles** in 4 fixing points: 2 in front (left + right) and 2 in the back (left + right)
2. **Horizontal "U" Profile** and **Back Support Profile** in 1 fixing point.



Keep the profiles firmly in place, throughout the drilling process, to avoid their repositioning.



# STEP 4

## INSTALLATION OF THE HORIZONTAL "U" PROFILE

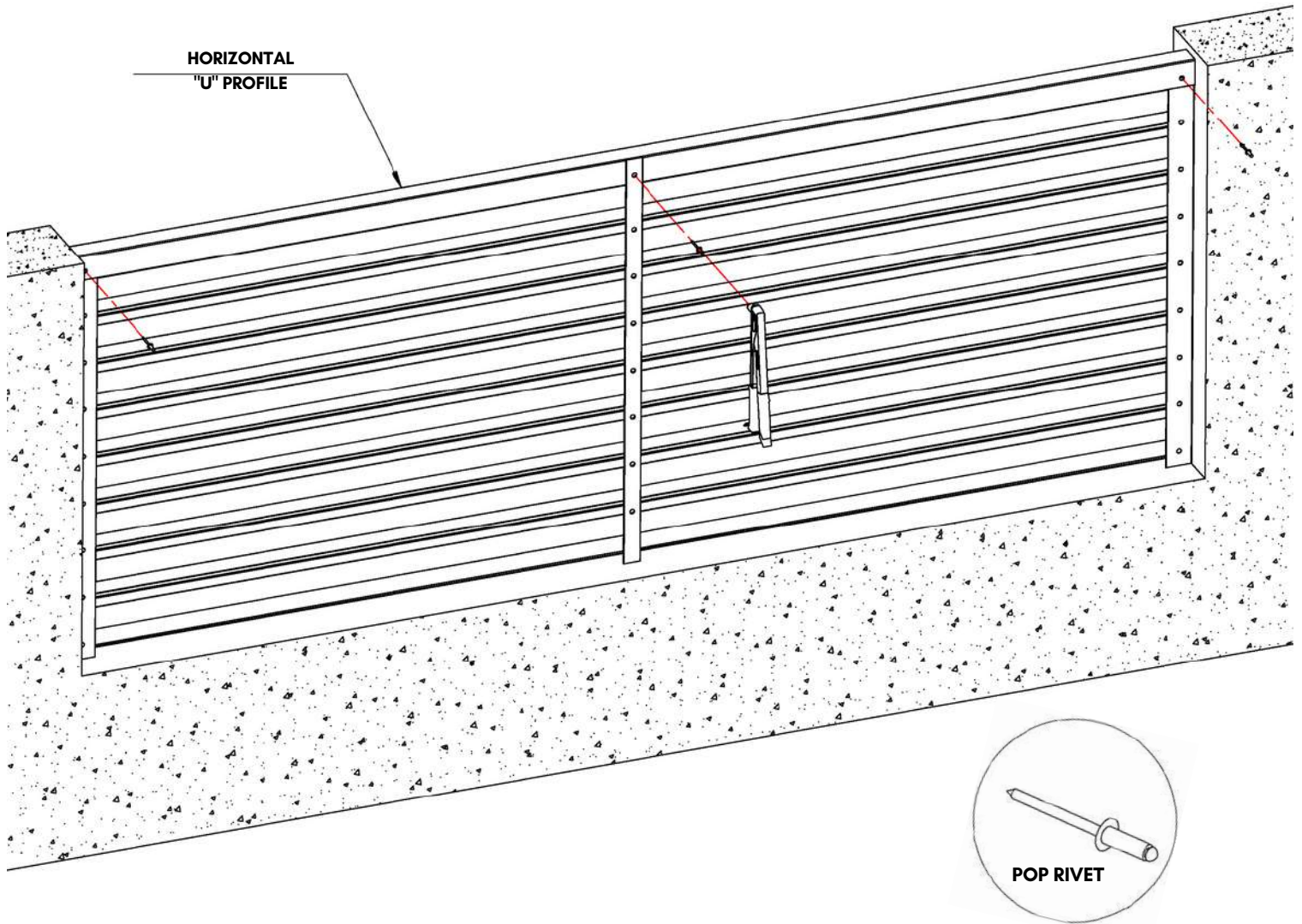

- 1 After finishing the drilling process, align the fixing holes of the Horizontal "U" Profile with those of the Vertical "U" Profiles and the Back Support Profile.

- 2 Insert the pop-rivet into the pliers / rivet gun.  
Place the Pliers / Rivet Gun perpendicular to the hole and rivet them in the fixing points drilled in the previous step.



Keep the profiles firmly in place, throughout the riveting process, to avoid their repositioning.

# ferro system

ferrosystem.com  
(425) 371 9121